

See discussions, stats, and author profiles for this publication at: <https://www.researchgate.net/publication/235274281>

A social networked learning adoption model for higher education institutions in developing countries

Article in *On the Horizon* · September 2011

DOI: 10.1108/10748121111179439

CITATIONS

79

READS

566

3 authors:



Munguatosha Maleko

Institute of Accountancy Arusha

1 PUBLICATION 79 CITATIONS

[SEE PROFILE](#)



Paul Birevu Muyinda

Makerere University

43 PUBLICATIONS 450 CITATIONS

[SEE PROFILE](#)



Jude Jude Lubega

Nkumba University (NU)

59 PUBLICATIONS 520 CITATIONS

[SEE PROFILE](#)

Some of the authors of this publication are also working on these related projects:



Distance Education Leapfrogging Project (DELP) [View project](#)



EBoML - Mobile Learning [View project](#)

A social networked learning adoption model for higher education institutions in developing countries

Godfrey Maleko Munguatosha, Paul Birevu Muyinda and Jude Thaddeus Lubega

Godfrey Maleko Munguatosha is based at the School of Computing and Informatics Technology, Makerere University, Kampala, Uganda.
Paul Birevu Muyinda is based in the Department of Open and Distance Learning, Makerere University, Kampala, Uganda.
Jude Thaddeus Lubega is based in the Department of Information Technology, Makerere University, Kampala, Uganda.

Abstract

Purpose – *The purpose of this paper is to establish a model for adopting social networked learning in higher institutions of learning in developing countries of Africa.*

Design/methodology/approach – *Mixed methods research methodology involving survey and interviews was adopted in the collection of data for building the model. The model was theoretically underpinned by the Technology Acceptance Model and the social constructivist learning theory, and was built and validated using structural equation modelling and Delphi techniques respectively.*

Findings – *Adoption of social networked learning in developing countries of Africa requires self efficacy, reliable technical and administrative support, infrastructure, system interactivity, adequate budgeting and accountability, and a flexible organisational culture.*

Practical implications – *The model provides a framework for integrating social software tools with the traditional learning systems of developing countries of Africa. This has a positive outcome of providing social constructivist information and communication technology (ICT) supported learning at low or no cost.*

Social implications – *The model has the potential to encourage formation of communities of practice to encourage development of social learning and a student-centered pedagogy.*

Originality/value – *The novelty of this research lies in the extension of the traditional technology acceptance models with constructs for proper budgeting and accountability and organisational culture. Time and other resources need to be devoted to developing social networked learning and the model takes this into account.*

Keywords *New learning media, Social software, Social networked learning, ICT-supported learning, Technology acceptance model, Structural equation modelling, Higher education, Developing countries*

Paper type *Research paper*

Introduction

Organizations continue to realize the significant impact that information and communication technologies (ICTs) have on their day-to-day business processes. In educational institutions, access to learning resources, real-time communication, and access to research sources can be simplified using ICTs (Kruger, 2010), and institutions can enhance classroom-based methods by integrating social learning methods into traditional approaches (Nichols and Anderson, 2005). In practice, ICT-supported learning can be viewed as web-supplemented, web-dependent, mixed mode or purely online learning system (Nichols and Anderson, 2005). Several ICT-supported learning systems have been developed (Hoppe and Breitner, 2004), and improved interaction, better access to resources, reduced operating costs and reliable communication among users are reported benefits of having an ICT-supported learning environment (Sife *et al.*, 2007).

Popular traditional ICT-supported learning management systems (LMS) include: WebCT, Scholar360, Blackboard vista and Moodle (Mazman and Usluel, 2009; Walsh, 2010). A current focus of ICT-supported learning systems is towards online, open, collaborative and

interactive learning to allow content sharing, and which is mobile enabled (Kruger, 2010). In this study, the focus is social networked learning which is enabled by new learning media through collaborative web platforms, which have evolved from web-based learning systems (Kumar, 2009).

The collaborative web is rich in applications that can facilitate knowledge sharing, interaction, collaboration and communication. These technologies provide for a way for collaboration and engagement of learners and educators in a common space around shared interests (Mazman and Usluel, 2009). They provide rich learning support in line with social theories of learning (Vygotsky, 1978) which emphasize personalization, collaboration, information sharing, common interests, active participation, and group work support (Mazman and Usluel, 2009). The collaborative Web therefore supports social networked learning in which learners use personal tools for self-directed and problem-based learning.

The collaborative web is supported by tools known as social software tools. Social software tools which support social learning include, among others: wikis, Weblogs, social bookmarking, RSS feeds, social networking sites (Facebook, Twitter, MySpace), podcasts, e-portfolios, video repositories, online office and tagging (Alexander, 2008; Awodele *et al.*, 2009). The use of these tools can enable higher education institutions to achieve social aspects of learning in line with social constructivist learning theory (Vygotsky, 1978).

Social software tools facilitate learning in various ways. For example, by using wikis, learners are able to participate actively by contributing to a topic of interest and collaborating in groups to share available resources (Ryan *et al.*, 2011). Blogs can provide a two-way communication tool for learners and educators to participate in online forums, chatting, content sharing using RSS feeds and commenting (Awodele *et al.*, 2009). For enhancing, sharing and collaboration, social bookmarking sites like del.icio.us, citeulike or diigo enable users to keep records of web pages on the web rather than in a standalone web browser. Social bookmarking can be used by researchers, educators, learners and non-learning organizations to share relevant content (Alexander, 2008). Other social software tools in education support audio sharing (for example, Skype) and multimedia sharing (for example, YouTube). Facebook, MySpace, Twitter and other social networking sites have potential to support social learning through community networking services such as wall posting, chatting, content sharing and tagging (Alexander, 2008).

Popular learning management systems now include these types of social software tools like blogs, online discussion forums, podcasting, multimedia sharing, chatting, RSS feeds, online community and wikis (Alexander, 2008; Awodele *et al.*, 2009). Social software tools that can be used to facilitate social networked learning can be classified as new learning media (Kroop *et al.*, 2010), most of which are available for free, or at low cost.

Despite the enormous potential and apparent cost effectiveness of new learning media for facilitating social networked learning, however, its application by institutions of higher learning in developing countries of Africa is low (Ndume *et al.*, 2008). As such, the use of new learning media in countries like Tanzania, for example, is still at its infancy.

To achieve the goals of infusing social networked learning into traditional pedagogical approaches, several conceptual models have been developed (Venkatesh and Bala, 2008). However, these new learning media adoption models do not often factor in learning contexts prevalent in developing countries like Africa. Learning context is a factor that must be addressed in any learning process (Uden, 2007). The benefits of social networked learning can only be attainable if drivers and inhibitors of new learning media within any given geographical, economic, social, cultural and technological contexts are explicit (Alexander, 2008; Mazman and Usluel, 2009). Given time and technological changes and environmental, economic, political, cultural and social differences among communities, models must be adapted to reflect local contexts (Venkatesh and Bala, 2008). For instance, low ICT literacy levels, limited bandwidth, cultural encumbrances, higher poverty levels, low reading culture, among others, are key context issues with relevance to any learning model

for developing countries of Africa (Farrell and Isaacs, 2007). Furthermore, a model for social networked learning should be derived from knowledge of intended users (Abbad *et al.*, 2009). This paper builds a model to support the adoption of social networked learning in African countries, based on a study conducted in Tanzania.

Tanzania is located in the Eastern part of Africa and has two categories of institutions of higher learning: accredited universities managed by the Tanzania Commission for Universities (TCU), and technical colleges managed by National Council for Technical Education (NACTE). ICT-supported learning has penetrated most of these institutions, although at low levels (Ndume *et al.*, 2008). Institutions such as the University of Dar Es Salaam (UDSM), Sokoine University of Agriculture, Muhimbili University of Health and Allied Sciences, Open University of Tanzania, Ardhi University and Mzumbe University use ICT-supported learning, but it is generally yet to be fully adopted (Sife *et al.*, 2007).

Only UDSM has implemented online learning based an LMS. Use of this LMS is, however, intermittent due to inability to pay its annual licences and limited technical skills to use it (Sife *et al.*, 2007). Due to these challenges, UDSM also runs the open source Moodle LMS in parallel with the proprietary Blackboard LMS. In other institutions, Moodle LMS, intranet portals, students and staff webmail, ARIS (record keeping) and Zalongwa Academic Registrar Information System (ZARIS) are commonly used. No literature is available on the use of new learning media in higher institutions of learning in Tanzania, and this paper seeks to provide data through the development of a social networked learning adoption model.

This paper is organised in five major sections. Section 1 introduces the paper. Section 2 examines related literature. Section 3 details the methodology used for developing the social networked learning model. In Section 4, we present and discuss results from the study and adduce relevant constructs for building and validating the model. In Section 5, we conclude our study and provide direction for future research.

2. Related literature

2.1 ICT-supported learning evolution

When considering ICT-supported learning, one should be specific about the sector for which it is being defined. Generally, ICT-supported learning is regarded as a new form of learning which utilizes the internet and other ICTs for content access and delivery of a wide range of digital materials, communication, interaction and collaboration across distant communities (Prensky, 2010, Nichols and Anderson, 2005). According to Nichols and Anderson (2005), the aim of ICT-supported learning is to provide new and improved ways of learning. ICT-supported learning has evolved from print-based distance learning to the current social learning media or new learning media which is enabling social networked learning.

2.2 Social networked learning

Social networked learning refers to learning using new learning media commonly referred to as social software tools (Kruger, 2010). Social software tools which support social networked learning include, among others: wikis, Weblogs, social bookmarking, RSS feeds, social networking sites (Facebook, Twitter, MySpace), podcasts, e-portfolios, del.icio.us, YouTube, Skype, flickr, online office and tagging (Alexander, 2008; Awodele *et al.*, 2009).

Social software tools connect learners in the virtual space enabling them to interact and collaborate as they execute learning activities. By participating in social networked learning, learners are actively engaged in the learning process and experience flexible environments for communication, global information sharing, personalized learning and independent learning with respect to place and time (Kruger, 2010; Mazman and Usluel, 2009). Social networked learning enables borderless learning, and its focus is toward learner-centred and process driven learning environments as opposed to content-driven learning (Nichols and Anderson, 2005). Walsh (2010) indicates that in social networked learning, there is increased social motivation for students to read and contribute through online discussions.

Learners with similar interests are now able to connect themselves globally in social and learning communities (Cain, 2008). Social software tools have the potential to support social and personalized learning (Awodele *et al.*, 2009); however, because of the rich functionality provided by these tools, higher education institutions need to ensure that how to use these tools effectively is clear to both learners and educators (Kroop *et al.*, 2010).

Social software tools are used in education in two ways - as separate tools like wikis and blogs or as integral parts in latest versions of LMSs (Kruger, 2010). Research conducted in San Diego State University reveals the potentials of blogs, wikis and discussion boards as effective collaborative learning tools embedded in their online LMS. Alexander (2008) has also conducted a study to evaluate the benefits of using social software tools as separate tool or as tools integrated in LMS. The Ning.com community network software was successfully integrated with Blackboard vista LMS to provide collaborative, social and more personalized learning in Dubai Men's College (Mazman and Usluel, 2009).

2.3 Social networked learning success factors

As has already been discussed, social networked learning is a form of ICT-supported learning which uses new learning media (Kruger, 2010). As such, success factors for traditional ICT-supported learning cascade to social networked learning. Researchers have been developing adoption and diffusion models by associating the determinant factors required to guarantee return on investment in ICT-supported learning systems.

If institutional policies, stakeholder involvement, reliable infrastructure, and balanced funding are guaranteed, then ICT-supported learning is more likely to be used (Nichols and Anderson, 2005). Ndume *et al.* (2008) argue that administrative support, learning methodology, infrastructure availability, awareness, change management, and intellectual investment must be address to guarantee success of ICT-supported learning.

Khan (2001) suggested eight dimensions for effective e-learning, which includes: institutional support, pedagogical support, interface design considerations, proper evaluation, management support, resource support, ethical considerations and technological support.

Across these models, infrastructure is a common thread. Unwin (2008) suggests that infrastructure such as electricity, computers and internet access, systems reliability and availability are key success factors for ICT-supported learning.

2.4 Social networked learning in developing countries of Africa

Very little research has been conducted about social networked learning in less developed countries. Awodele *et al.* (2009) undertook research in Nigeria in which they found that wikis, blogs, RSS feeds and social bookmarking were successfully being used to facilitate social networked learning. Affordable and modern learning models supported by social software tools need to be devised for countries such as Africa.

However, developing countries of Africa are characterized by limited access to ICT-supported learning facilities, limited bandwidth, high ICT illiteracy levels, high poverty levels, lack of or intermittent power supply and lack of appropriate ICT-supported learning policies and sustainability plans (Farrell and Isaacs, 2007). Most of the literature on social networked learning is from developed countries whose technological, economical, social, political and cultural setup are quite different from those in developing countries like Tanzania. By borrowing from existing social networked learning literature and undertaking research on social networked learning in Tanzania, this paper has developed a model for social networked learning adoption for developing countries in Africa.

2.5 Theoretical approaches to social networked learning

According to social learning and development theories, it is believed that individual social behaviour and socialization are fostered by social interaction, consciousness and social cognition (Vygotsky, 1978). Connections between people and the socio-cultural context in

which they act and interact with others frequently provides the basis for personal learning and social development (Crawford, 1996), and group collaboration plays a very fundamental role in building cognition (Vygotsky, 1978).

Vygotsky's social development theory states that:

Every function in the child's cultural development appears twice: first, on the social level, and later, on the individual level; first, between people (interpsychological) and then inside the child (intrapsychological). This applies equally to voluntary attention, to logical memory, and to the formation of concepts. All the higher functions originate as actual relationships between individuals (Vygotsky, 1978, p. 57).

This theory further postulates that learning occurs when learners are fully engaged in social interaction. The concept is referred to as "Zone of Proximal Development" which asserts that skills obtained collaboratively exceeds skills obtained individually.

Vygotsky's theory forms the basis for the social constructivist theories of learning which claim that learning is an active and constructive process (Vygotsky, 1978). The social constructivist approach is based on tenets that learning is self-governed, problem-based and collaborative. According to Alexander (2008), social software tools can support a social constructivist approach to networked learning by providing learners with personal tools that can engage them in social networking, and that support group interaction and collaboration. Learning is a social process which demands interaction and collaboration (Panday, 2009). The core activities in the learning process include, but are not limited to: problem solving by students and collaboration and students self-management. Unlike classroom and traditional LMS-based learning, the emphasis of social networked learning is to transform traditional learning beyond educator-centred learning to achieve learner-centred, problem-based and collaborative learning environments (Alexander, 2008). As such, this form of learning focuses on understanding learners' views and feelings and on creating conducive environments towards problem solving other than just imparting knowledge to them (Nichols and Anderson, 2005).

2.6 Social networked learning adoption and utilization models

Since ICT-supported learning systems are a technological information system, their adoption and/or diffusion should also be addressed from an information systems point of view (Abbad *et al.*, 2009). The literature (for example, Abbad *et al.*, 2009; Lee, 2006; Park, 2009) indicates that the Technological Acceptance Model (TAM) has been widely used to underpin the adoption and utilisation of information systems. Similarly, the adoption of social networked learning systems can be understood by application of the TAM.

Since TAM's inception in 1989, it has become the most popular theoretical model used in the information systems field worldwide to describe users' acceptance or rejection of information systems (Lee *et al.*, 2003). By 2003, more than 698 research based journal articles applied the TAM (Lee *et al.*, 2003). According to Davis *et al.* (1989), "Perceived usefulness of the system" and "Perceived ease of use of the system" are the key determinant factors towards "User intention to use the system". TAM identifies causal relationships between system design variables, perceived usefulness of the system, perceived ease of use of the system, individual's attitudes towards the use of the system and actual usage behaviour.

According to Mazman and Usluel (2009) and Davis *et al.* (1989), the main idea behind the TAM is that, people tend to accept or reject technology to the extent they believe it is helpful in performing their job better (i.e. perceived usefulness) and if a user believes that learning to use that technology in place is free of effort (i.e. ease of use). Generally perceived ease of use (PEOU) of the system, perceived system usefulness (PSU), user intention to use the system (UIUS) and user subjective norms (USN) towards the system in place are the key factors in building technology utilisation models (Davis *et al.*, 1989; Venkatesh *et al.*, 2003). TAM has evolved from TAM I to TAM II.

Adoption models specific to social networked learning include: Unified Theory of Acceptance and Use of Technology (UTAUT), which is derived from eight prominent technological adoption theories/models. These prominent theories/models include:

1. Diffusion of Innovation Theory (DIT);
2. Theory of Reasoned Action (TRA);
3. Theory of Planned Behaviour (TPB);
4. TAM;
5. Combined TAM and TPB;
6. Motivational Model;
7. Social Cognitive Theory;
8. Model of PC Utilization and their extensions (Venkatesh *et al.*, 2003).

All these theories/models are extended from the basic principles of TRA which believes that intention to use the system is the function of attitude towards individual behaviour and subjective norms which was later extended to include perceived control and hence TPB (Venkatesh and Bala, 2008).

2. Methodology

This paper uses the Technology Acceptance Model (TAM) to underpin the development of a social networked learning model for developing countries of Africa. The study reported here adopted a mixed methods research approach involving a survey and interviews. The study was conducted in higher learning institutions in Tanzania.

The population of the study included students, administrators, tutors, executives and professional technical personnel. The sample size ($n = 1,588$) was determined using the formula:

$$n = \frac{N}{1 + Ne^2}$$

Where:

n = the sample size.

N = the total population.

e = the sampling error.

A stratified sampling technique was used to select institutions from zones across the country, considered as a stratum. Simple random sampling was then used to select the sample from each stratum. A total of 70 key informants in the study were purposively selected and interviewed. Of the anticipated survey response of 1,588, 1,230 were returned representing a response rate of 77.5 per cent. Of the returned responses, 65.0 per cent were from students, 30.6 per cent from tutors and 4.4 per cent from administrators. Survey results were triangulated with interview results.

The survey questionnaire consisted of five point Likert scales (Likert, 1932) with questions for measuring the degree to which respondents believed that new learning media was useful in their daily activities. Likert scale questions are recommended for studies aimed at assessing attitudes towards new technology use in education (Rovai, 2002). Interview data was analysed qualitatively to identify the different factors and aspects relating to the use of social networked tools in higher education in Tanzania. From the quantitative data, descriptive and inferential statistics were generated to adduce constructs for building the model.

Using SPSS, the five-point Likert scale variables were each weighted to obtain their summed scores before being analysed to obtain their p-values and regression coefficients for building the model.

To test the reliability of survey items, Cronbach's alpha (α) test (Cronbach, 1951) was employed. Survey items with $\alpha > 0.7$ were retained in the survey because they were reliable to generate data for the model.

The model was built using Structural Equation Modelling (SEM) approach (Bollen, 1998; Hoyle and Panter, 1995) with three different regression models – Perceived System Usefulness (PSU), Perceived Ease of Use (PEOU) and User Intention (UI) to use the system. The emphasis for SEM is to assess the relationships between the three variables (Hair *et al.*, 2006). The initial model constructs were established by using previous studies for TAM and Extended TAM models, which were finally refined using findings from the survey and interview.

To validate the model, the Delphi Technique was employed (Harold and Murray, 1975). The Delphi Technique involves use of experts to evaluate the usability of an artefact. Three workshops involving ICT-supported learning experts and practitioners from 20 institutions of higher learning in Tanzania were conducted in which summary scores on the model for each workshop were recorded to compute the final scores. Then mean scores were obtained to develop the new model (Rowe and Wright, 1999).

4. Results and discussion of findings

Results are presented following the tenets of the TAM. The data were analysed based on the key determinant factors towards TAM, including:

- perceived ease of use of new learning media;
- perceived usefulness in education; and
- user readiness to use new learning media.

4.1 *New learning media experience among private and public institutions*

The majority (85 per cent) of interview respondents from private institutions were more exposed to new learning media compared to those from public institutions, where only 40 per cent had experienced new learning media. Experience with new learning media was measured based on whether one had ever used it for learning or teaching, attended a course on new learning media, heard about it from a colleague from another institutions or seen a colleague using it. These results match with previous studies by Alexander (2008) and Mazman and Usluel (2009) which found that the more a person is involved in Internet or Web activities, the more they are likely to use new learning media. It is therefore more likely that, in developing countries social networked learning will grow faster in privately owned institutions which can afford to implement these technologies, compared to public institutions.

When asked why they would wish to adopt new learning media, an interviewee said, "... as a private university, we strive to make a difference and attract students. We are always on the look out for innovations". Another said, "... we must be up-to-date with technology as a private university". On the other hand, an interviewee from a public university said, it is up to the Ministry of Education to introduce this form of pedagogy to us".

4.2 *New learning media experience among students, administrators and tutors*

The majority (89 per cent) of students and administrators were aware of the use of social software tools in their day-to-day activities, compared to only 45 per cent of tutors who were aware of them. However, even though awareness about social software tools was high among students and administrators, only 35 per cent of them were using them in formal learning activities, while 65 per cent were using them in non-learning activities for chatting,

collaborating with friends, conducting online forums, blogging, wall postings, social bookmarking, and photo tagging. Very few respondents (2.5 per cent) were found using wikis and podcasts.

Survey respondents were willing to use social networked learning. When asked to give their views towards use of social software tools for learning, one of them said, "I feel very comfortable using social software sites like YouTube as I get everything about my studies in addition to socialization". Another said, "I enjoy visiting social networking sites as they are very easy to use and everyone can gain access and join groups of interest free of charge". This is evidence enough to show that respondents prefer learning media that enhance collaborative and interactive learning, social grouping, cost effectiveness, free access, multimedia sharing and blogging. These are characteristics of new learning media.

Respondents named the new learning media they prefer for social networked learning, including social networks such as Facebook, MySpace and Twitter, multimedia sharing such as YouTube, social bookmarking sites such as delicious, citeulike and general blogs such as Jamiiforum.com. Respondents were willing to use these tools independently or as integrated tools in current LMS like Moodle. One student said, "I can see new learning has now been born" which is in line with the view that new learning media has brought about a new learning paradigm (Ndume *et al.*, 2008). Another student wrote, "We are now joining the World of 'B' for Blogging, 'F' for Facebook, 'Y' for YouTube . . ."

4.3 Educational information systems adopted in Tanzania

Moodle was the most (78 per cent) commonly used LMS in private and government owned institutions. Other LMSs were ZARIS (11 per cent), ARIS (8.5 per cent) and Blackboard (2.5 per cent). In addition, intranet portals, Outlook and e-mail systems were used in various student and staff support services. No institutional wide adoption of new learning media was reported. Mazman and Usluel (2009) asserted that it is easier to transform a user of traditional information systems into being a user of a new learning system; hence it is likely that those using existing educational information systems might more readily adopt new learning media in their teaching and learning processes.

4.4 Factors for adoption of new learning media

The study revealed that security and privacy in social networked learning, infrastructure, technical and administrative support were key factors for adoption of social networked learning in Tanzania.

4.4.1 Security and privacy in social networked learning. Respondents expressed many concerns about the security and privacy of information if social networked learning was to be adopted. Tutors (85.8 per cent) and administrators (65.2 per cent) doubted whether security and privacy of online profiles, postings and photos would be guaranteed. One of them said, "I have a Facebook account in which I use informally, but I can feel the way it is flexible to access someone else's information including photos, personal profiles and even wall postings" Another said, "YouTube is my HERO; I can freely download videos of my topic before I go for lectures". While there is great hope for new learning media, respondents suggested that although learning can be done in a digital environment, there is still room for institutions to filter and apply security measures against both incoming and outgoing content. Issues of ownership and control will become more complicated as content is increasingly freely shared and being re-used worldwide (Prensky, 2010). It is time for organizations to re-define security boundaries as work of all kinds is increasingly being done over the Internet through openness, sharing and free access (Prensky, 2010).

4.4.2 Technical support and infrastructure. About 86 per cent of the respondents reported lack of enough technical support and reliable infrastructure to support new learning media. Lack of reliable power supply and internet connection, and limited supply of computers were

mentioned as major infrastructure constraints. Lack of competent technical staff, poor communication among technical personnel and users, irrelevant ICT policies, lack of exposure and irregular professional training for technical staff were the technical support related challenges for adopting new learning media. Ease of use of any system is mainly facilitated by having reliable technical support and infrastructure (Khan, 2001). Several researchers (e.g. Ngai *et al.*, 2007) have extended the TAM to include these factors as the main constructs for their technology adoption models.

4.4.3 Administrative support. Most executives of higher learning institutions in Tanzania were technophobic towards application of information technology in their day-to-day activities. Out of the 70 executives interviewed, only 35 per cent were comfortable with the use of ICT enabled facilities in their offices. This situation is disappointing, considering the fact that the Government of Tanzania had recently put more emphasis on ICT services and application. Further, such a situation is detrimental to the development of ICTs in education. It suggests the need for user education and the provision of regular executive training. It is believed that an executive who is aware of ICT benefits to his/her business will emphasize and support adoption and full use of ICTs in their institutions. The same results were obtained in the ICT-supported learning research in Tanzania, in which administrative support was important in ICT adoption (Ndume *et al.*, 2008). This is also in line with Khan (2001) who asserts that e-learning development should link back into the institution's mission, and that institutions must have strategies that are enterprise-wide in scope. Once this is achieved, executives should be able to see the value of new learning media adoption in their faculties.

4.5 Views for effective utilization of new learning media

Findings from the Cronbach's alpha test returned technical support, administrative support, self-efficacy, internet experience, infrastructure and security as being reliable determinant factors for the adoption of new learning media. Each of these variables was weighted and its *p*-values generated at 5 per cent level of significance. At this level of significance for Intension to Use social software tools in education, *p* = administrative support (*p* = 0.0021), infrastructure (*p* = 0.0015), technical support (*p* = 0.0042), self-efficacy (*p* = 0.0008) and system interactivity (*p* = 0.0025) were found to be significant factors for social networked learning. Budgeting and accountability (*p* = 0.0267) and organization culture (*p* = 0.0354) were also found to be significant factors. Security and privacy of information and internet experience were found to be non-significant at *p* = 0.0512 and 0.0631 respectively. This can be attributed to lack of mission critical data in their current systems warranting cutting edge security and the belief that everyone can gain experience once the systems are fully operational. These results are consistent with the findings by Borgatti and Cross (2003) in which administrative support, technical support and self efficacy were found to be mission critical factors towards adoption of social network sites in education.

4.6 The social networked learning adoption model

With the determinant factors adduced in Section 4.5 above, Structural Equation Modelling (SEM) approach (Bollen, 1998; Hoyle and Panter, 1995) was used to determine the cause-effect relationships among determinant factors for use of social software tools in education. Three regression models were developed based on their actual factor-dependencies. The regression models were developed for Perceived System Usefulness (PSU), Perceived Ease of Use (PEOU) and User Intensions (UI). PSU dependent factors were Self Efficacy (SE) towards new learning media, ones experience in the use of web and internet (IE), availability of reliable technical support in case of difficulties (TS), perceived mental belief that the system can be learnt in short period of time and with less effort (PEOU), and infrastructure (I) in terms of electricity, computers and internet access (I). Other constructs were user friendliness of the new learning media, the culture of the institutions in terms of ethics for accessing online resources (OC), budget planning and allocation to ICT projects and accountability of those leading higher learning communities

(BA) which are constructs towards Intension to Use social software tools in education. Based on the findings, the initial regression models were as follows:

$$PSU = 0.501SE - 0.071IE + 0.210TS + 0.141AS + 0.108EOU + 0.111I \quad R^2 = 0.859$$

$$PEOU = 0.301SE + 0.2002SI + 0.1015TS + 0.152AS + 0.113I + 0.102BA + 0.0310OC \\ R^2 = 0.684$$

$$UI = 0.359PEOU + 0.641PSU \quad R^2 = 0.896$$

where:

OC = Organization culture.

BA = Budgeting and accountability.

SE = Self-efficacy.

IE = Internet experience.

TS = Technical support.

AS = Administrative support.

I = Infrastructures.

SI = System interactivity.

The entire model was found to have a significant fit for the study as all the three regression models have $R^2 \geq 0.5$ (Hoyle and Panter, 1995).

From the findings above, it is clear that, self-efficacy (50.1 per cent), technical support (21.0 per cent), administrative support (14.1 per cent), ease of use of the social software tools (10.8 per cent) and infrastructures (11.1 per cent) are the key factors for one to realize how the system is useful to their learning processes. In addition to these factors, system interactivity (20.2 per cent) has an influence on ease of use of social software tools. These results agree with those in Abbad *et al.* (2009) in which technical support, self efficacy and system interactivity were found to be significant determinant factors.

Context specific constructs revealed in this research include: organizational culture (3.1 per cent) and budgeting and accountability (10.2 per cent) especially in government owned institutions. The culture of the organization determines the permissible online resources accessible by its people. In Tanzania, for instance, it is common to find access to social sites like YouTube, Facebook or Twitter blocked. In so doing, access to education is blocked (Prensky, 2010). There should be flexible cultural practices in higher learning communities if they are to benefit from social networked learning.

4.7 Model validation

Using the Delphi Technique, the new model espoused in Section 4.6 above was validated. The Delphi Technique is based on the assumptions that group expert judgement is better than individual judgement (Amiresmaili *et al.*, 2011). Therefore, three workshops composed of panels of ICT-supported learning experts from 20 institutions of higher learning in Tanzania were conducted to discuss and evaluate the model. The experts were technical personnel, executives of higher learning and consultants of learning media. All relevant determinant factors obtained from Section 4.6 were critically discussed by panellists and compared. The expert judgement arising was used to test the validity of the model which was then refined using inputs from the workshop. The model finally established is a function of individual self efficacy (SE) in learning social software tools, availability of technical support (TS) in case of difficulties, administrative support (AS) from the chief executives of higher learning institutions, system interactivity (SI) of new learning media (e.g. YouTube), reliable infrastructure (I) in terms of electricity, computers and access to the internet, flexible organization culture (OC) and budgeting and accountability by the administrators. Being

non-critical, individual experience in the use of Internet and security and privacy of information were not included in the final model as shown in Figure 1.

This social networked learning adoption model presents several advantages for developing countries. The model can to a large extent reduce total cost of acquiring and managing ICT-supported learning tools since access to social software tools is largely free of charge, making it an affordable option for developing countries of Africa whose per capita income is on average below US \$1,000. Also, implementation of the model has the potential to improve interactivity, collaboration, reliable resource sharing, access to online resources, and resources re-usability. In so doing, the model will enable the much sought for social constructivist learning (Vygotsky, 1978).

The novelty in our model lies in the extension of existing information system usability models through the Budgeting and Accountability and Organisational Culture dimensions. Time and other resources need to be set aside for social networked learning. All resources invested in social networked learning must be properly accounted for and there should be a flexible organisational culture to permit social networked learning.

3. Conclusion and future research

The goal of this research has been achieved through the development of a model for social networked learning adoption in developing countries of Africa. The time is now for developing countries like Africa to realize the potential of social software tools and use them formally in the learning process (Ndume *et al.*, 2008).

Results obtained through a mixed research methods approach revealed that Self Efficacy (SE), Technical Support (TS), Administrative Support (AS), Infrastructure (I), System Interactivity (SI), Budgeting and Accountability and Organisational Culture are important ingredients a model for social networked learning. In particular, Budgeting and Accountability and Organisational Culture are novel additions to learning technology utilisation models. The model is vital for enabling institutions of higher learning in developing countries to partake of social constructivist ICT-supported learning in cost effective fashion, which is vital for countries with low per capita incomes.

The implication of our study is that social learning models, if properly implemented, can lead to increased knowledge generation through social interaction and collaboration. Educational system developers need to consider how to integrate more social networking

Figure 1 A model for social networked learning adoption

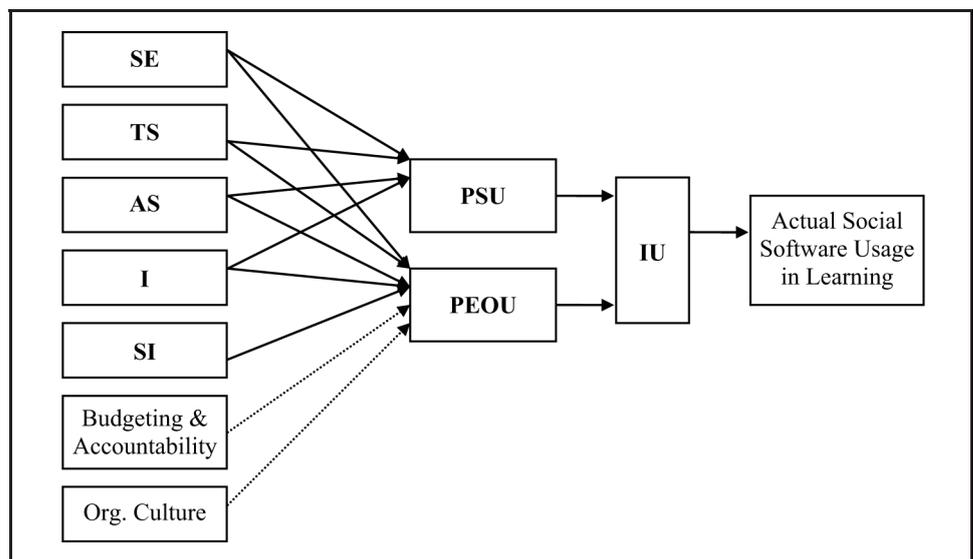

tools into traditional learning management systems to enable social networked learning. The model developed in this paper provides a framework for this integration.

The limitation to this study is that data was drawn from one country, on the assumption that all developing countries in Africa have similar learning contexts as Tanzania. Future research on social networked learning in Africa should focus on drawing a more comprehensive sample involving at least one country from each region of Africa. Research is needed to explore security and privacy of information issues in new learning media in education. Further, the need to carry out research to determine the influence of internet experience and subjective norms towards adoption of new learning media is important.

References

- Abbad, M.M., Morris, D. and Nahlik, C. (2009), "Looking under the bonnet: factors affecting student adoption of e-learning systems in Jordan", *The International Review of Research in Open and Distance Learning*, Vol. 10 No. 2, pp. 1-22.
- Alexander, B. (2008), "Social networking in higher education", available at <http://net.educause.edu/library/pdf/PUB7202s.pdf> (accessed 11 November 2010).
- Amiresmaili, M., Tourani, S., Esfandiari, A. and Feyzabadi, V.Y. (2011), "A model for health services priority for Iran", *Journal of American Science*, Vol. 7 No. 4.
- Awodele, O., Idowu, S., Anjorin, O., Adedire, A. and Akpore, V. (2009), "University enhancement system using a social networking approach: extending e-learning", *Issues in Informing Science and Information Technology*, Vol. 6 No. 1, pp. 269-83.
- Bollen, P.M. (1998), *Structural Equations with Latent Variables*, Wiley, New York, NY.
- Borgatti, S.P. and Cross, R. (2003), "A relational view of information seeking and learning in social networks", *Management Science*, Vol. 49 No. 4, pp. 432-45.
- Cain, J.E. (2008), "Online social networking issues within academia and pharmacy education", *American Journal of Pharmaceutical Education*, Vol. 72 No. 1, pp. 1-7.
- Crawford, K. (1996), "Vygotskian approaches to human development in the information era", *Educational Studies in Mathematics*, Vol. 31, pp. 43-62.
- Cronbach, L.J. (1951), "Coefficient alpha and the internal structure of tests", *Psychometrika*, Vol. 16, pp. 297-334.
- Davis, F.D., Bagozzi, R.P. and Warshaw, R.P. (1989), "User acceptance of computer technology: a comparison of two theoretical models", *Journal of Management Science*, Vol. 35 No. 8, pp. 982-1003.
- Farrell, G. and Isaacs, S. (2007), *Survey of ICT and Education in Africa. A Summary Report Based on 53 Country Surveys*, available at: <http://akgul.bcc.bilkent.edu.tr/egitim/ict-africa-survey.pdf> (accessed 16 May 2011).
- Hair, J., Black, B., Babin, B., Anderson, R.E. and Tatham, R.L. (2006), *Multivariate Data Analysis*, Prentice Hall, Englewood Cliffs, NJ.
- Harold, A.L. and Murray, T. (1975), *The Delphi Method: Techniques and Applications*, Addison-Wesley, Reading, MA.
- Hoppe, G. and Breitner, M.H. (2004), "Business models for e-learning", *Conference Proceedings on E-learning: Models, Instruments, Experiences of the Multikonferenz Wirtschaftsinformatik 2004 (www.mkwi04.de) in Essen, Germany*.
- Hoyle, R.H. and Panter, A.T. (1995), *Writing about Structural Equation Models*, Sage, Thousand Oaks, CA.
- Khan, B. (2001), "Elements of e-learning", available at: <http://BadrulKhan.com> (accessed 20 April 2011).
- Kroop, S., Nussbaumer, A. and Fruhhman, K. (2010), "Motivating Collaborative Learning Activities by Using Existing Web 2.0 Tools", available at: <http://mature-ip.eu/files/matel10/kroop.pdf> (accessed 12 June 2011).

- Kruger, C.J. (2010), *Latest ICT Trends in Enhancing Education*, available at: <http://web.up.ac.za/ecis/SACLA2010PR/SACLA2010/Papers/SACLA029.pdf>, (accessed 27 January 2011).
- Kumar, R. (2009), "E-learning 2.0 social software tools: learning redefined", *Journal of Library Philosophy and Practice*, available at: <http://digitalcommons.unl.edu/cgi/viewcontent.cgi?article=1283&context=libphilprac> (accessed 24 October 2010).
- Lee, Y. (2006), "An empirical investigation into factors influencing the adoption of an e-learning system", *Online Information Review*, Vol. 30 No. 5, pp. 517-41.
- Lee, Y., Kozar, K.A. and Larsen, K.R.T. (2003), "The technology acceptance model: past, present, and future", *Communications of the Association for Information Systems*, Vol. 12 No. 1, pp. 752-80.
- Likert, R. (1932), "Techniques for measurements of attitudes", *Archives of Psychology*, No. 140.
- Mazman, S.G. and Usluel, Y.K. (2009), "The usage of social networks in educational context", *World Academy of Science, Engineering and Technology*, Vol. 49 No. 1.
- Ndume, V., Tilya, F.N. and Twaakyondo, H. (2008), "Challenges of adaptive e-learning at higher learning institutions: a case study in Tanzania", *International Journal of Computing and ICT Research*, Vol. 2 No. 1, pp. 47-59.
- Ngai, E.W.T., Poon, J.K.L. and Chan, Y.H.C. (2007), "Empirical examination of the adoption of WebCT using TAM", *Computers and Education*, Vol. 48 No. 2, pp. 250-67.
- Nichols, M. and Anderson, B. (2005), "Strategic e-learning implementation", *Journal of Educational Technology and Society*, Vol. 8 No. 4, pp. 1-8.
- Panday, P.P. (2009), "Simplifying podcasting", *International Journal of Teaching and Learning in Higher Education*, Vol. 20 No. 2, pp. 251-61.
- Park, S.Y. (2009), "An analysis of the technology acceptance model in understanding university students' behavioural intention to use e-learning", *Journal of Educational Technology and Society*, Vol. 12 No. 3, pp. 150-62.
- Prensky, M. (2010), "Why YouTube matters. Why it is so important, why we should all be using it, and why blocking it blocks our kids' education", *On The Horizon*, Vol. 18 No. 2, pp. 124-31.
- Rovai, A. (2002), "Sense of community, perceived cognitive learning, and persistence in asynchronous learning networks", *The Internet and Higher Education*, Vol. 5 No. 4.
- Rowe, G. and Wright, G. (1999), "The Delphi technique as a forecasting tool: issues and analysis", *International Journal of Forecasting*, Vol. 15 No. 4.
- Ryan, S.D., Magro, M.J. and Sharp, J.S. (2011), "Exploring educational and cultural adaptation through social networking sites", *Journal of Information Technology Education: Innovations in Practice*, Vol. 10 No. 1.
- Sife, A.S., Lwoga, E.T. and Sanga, C. (2007), "New technologies for teaching and learning: challenges for higher learning institutions in developing countries", *International Journal of Education and Development using Information and Communication Technology (IJEDICT)*, Vol. 3 No. 2, pp. 57-67.
- Uden, L. (2007), "Activity theory for designing mobile learning", *International Journal of Mobile Learning and Organization*, Vol. 1 No. 1, pp. 81-102.
- Unwin, T. (2008), "Survey of e-learning in Africa", available at: www.elearning-africa.com/Publications-survey/elearning-africa.pdf (accessed 29 June 2010).
- Venkatesh, V. and Bala, H. (2008), "Technology Acceptance Model 3 and a research agenda on interventions", *Journal of Decision Sciences*, Vol. 39 No. 2, pp. 273-315.
- Venkatesh, V., Morris, M., Davis, G. and Davis, F. (2003), "User acceptance of information technology: toward a unified view", *MIS Quarterly*, Vol. 27 No. 3, pp. 425-78.
- Vygotsky, L.S. (1978), *Mind and Society: The Development of Higher Mental Processes*, Harvard University Press, Cambridge, MA.
- Walsh, K. (2010), "Facebook as an instructional technology tool", available at: www.emergingedtech.com/2010/08/facebook-as-an-instructional-technology-tool/ (accessed 11 October 2010).

Further reading

Brown, C.V., DeHayes, D.W., Hoffer, J.A., Wainright, M.E. and Perkins, W.C. (2009), *Managing Information Technology*, Pearson International, Toronto.

Chang, V. and Guetl, C. (2006), "E-learning ecosystem (ELES) – a holistic approach for the development of more effective learning environment for small-to-medium sized enterprises (SMEs)", *Proceedings of the Inaugural IEEE International Digital Ecosystems Technologies Conference, Cairns, Australia*.

Dernl, M. and Motschnig-Pitrik, R. (2003), "Towards a pattern language for person-centered e-learning", *Proceedings of Society for Information Technology and Teacher Education International Conference (SITE 2003), Albuquerque, New Mexico, USA*.

About the authors

Godfrey Maleko Munguatosha is an MSc student in the School of Computing and Informatics Technology at Makerere University. He also lectures at the Institute of Accountancy in management information system, Web programming, database systems and e-services delivery. His MSc Dissertation is in the area of social networked eLearning.

Paul Birevu Muyinda holds a PhD in Information Systems specializing in eLearning in general and mLearning in particular. He is currently a Lecturer and Head, Department of Open and Distance Learning at Makerere University. His research interests are inspired by the need to integrate ICTs in open and distance learning student support systems. He has research interest in social media, eLearning, mLearning and open and distance learning. Paul Birevu Muyinda is the corresponding author and can be contacted at: mpbirevu@iace.mak.ac.ug

Jude Thaddeus Lubega holds a PhD in Computer Science (eLearning). He is a member of the British Society and Hong Kong Web Society. He is the Head, Department of Information Technology in the School of Computing and Informatics Technology. His research includes: tracking and assessment in eLearning, social networked eLearning, e-content authoring, multi-agent systems, web-based systems and mLearning.

To purchase reprints of this article please e-mail: reprints@emeraldinsight.com
Or visit our web site for further details: www.emeraldinsight.com/reprints